

ORIGINAL INSTRUCTION

Use of the Machine

Purpose

This machine is designed for moulding along and across the grain of prepared timber, using cutters and limiters.

Operator Qualifications/Training

Operators of this machine should have a suitable qualification in the use of woodworking machinery, including spindle moulders or should have been trained by someone holding such qualifications.

GENERAL SAFETY RULES

WARNING:

Do not attempt to operate the machine until you have read thoroughly and understood completely all instructions, rules, etc. contained in this manual. Failure to comply may result in accidents involving fire, electric shock, or serious personal injury. Keep this owner's manual and review it frequently for continuous safe operation.

1. **Know your machine.** For your own safety, read the owner's manual carefully. Learn its application and limitations, as well as specific potential hazards pertinent to this machine.
2. Keep guards in place and in working order. If a guard must be removed for maintenance or cleaning, make sure it is properly replaced before using the machine again.
3. Keep your work area clean. Cluttered areas and workbenches increase the chance of an accident.
4. Do not use power tools in damp or wet locations, or expose them to rain.
5. Keep work areas well illuminated.
6. Keep children away.
7. All visitors should be kept a safe distance from the work area.
8. Make workshop childproof. Use padlocks, master switches and remove starter keys.
9. Do not force the machine. It will do the job better and be safe at the rate for which it is designed.
10. Use the right tools. Do not force the machine or attachments to do a job for which they are not designed.
11. Wear proper apparel. Avoid loose clothing, gloves, ties, rings, bracelets, and jewelry which could get caught in moving parts. Non-slip footwear is recommended.
12. Always use safety glasses. Normal spectacles only have impact resistant lenses. They are not safety glasses.
13. Maintain machine in good condition. Keep machine clean for best and safest performance. Follow instructions for lubrication and changing accessories.
14. Never leave the machine running unattended. Turn the power off. Do not leave the machine until it comes to a complete stop.
15. Always wear a face or dust mask if operation creates a lot of dust and/or chips. Always operate the tool in a well ventilated area and provide for proper dust removal. Use a suitable dust extractor.

Specification

Motor:	230/400,50Hz,1500W
Table size:	600X400mm
Roller table:	400x250mm
Working height :	860mm
Spindle diameter	30mm
Height adjustment of spindle:	105mm
Max. tool diameter:	150mm
Table opening:	170mm
Spindle speed:	1400/4000/6000/8000rpm

GETTING TO KNOW YOUR MACHINE

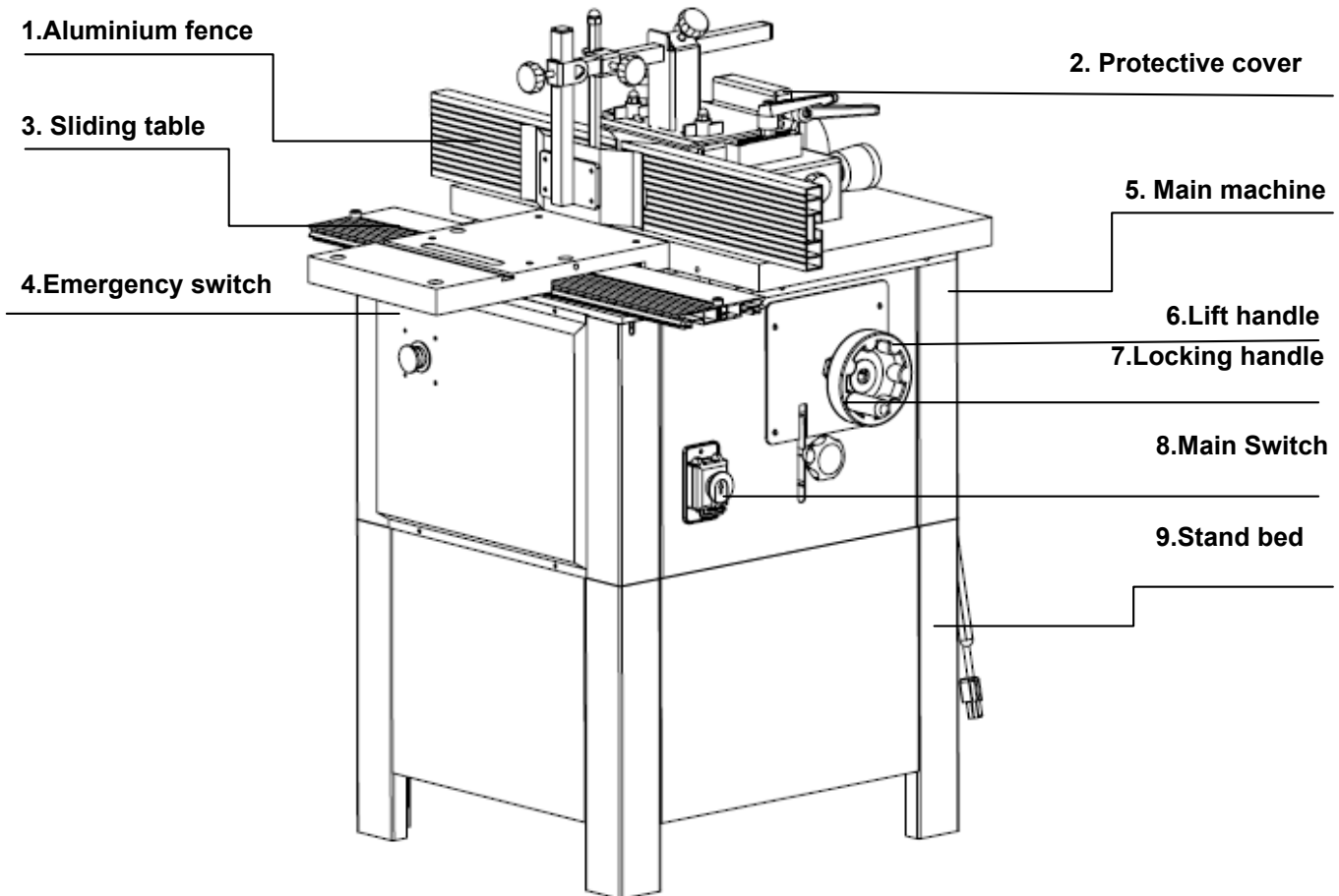

Unpacking

Main machine is packed in a plywood case.



Cut the strapping and lift the lid of the crate from the base. Remove the loose items surrounding the machine and those stored in the base of the machine. These can be accessed through the opening door situated on the left hand side of the machine.

	<p>In the cutter block recess you will find the 30mm spindle arbor and the routing collet, which will take 1/2" shank diameter router cutters.</p>

Assembly

	<p>Tilt the machine, prop it with a timber block and tighten the two feet with a spanner.</p> <p>Remove the block, repeat the procedure on the other side.</p> <p>Use a spanner to adjust the feet so that the machine is level</p>
--	---



Remove one of the stop screws from the sliding carriage rail.



Before fitting the sliding carriage it should be noted that the two outboard bearing wheels are mounted on eccentrics.



Should it ever be necessary their position can be adjusted with the aid of a 14mm spanner.



Slide the sliding table on to the guide rail, ensuring the guide rollers engage with the channels running either side of the rail.



Place the cross cut fence with the open side face down and the plastic tip to the right. Slide the pivot block and the locking block onto the back side of the fence with the head of the bolt in the T-slot. The Locking block has a T-shaped foot plate, slide it into the slot in the table. The Work clamp passes through the pivot block and locates in the large hole at the front of the carriage.



Fit the flip-over length stop by feeding the head of the bolt into the T-shaped slot on the top side of the fence.
The ratchet handle locks the stop in place.
The stop plate can be flipped over to engage or disengage it.



From underneath the carriage, push up the locating stop pin.



Use a square to check the crosscut fence is set at 90 degrees to the blade when it is pressed against the stop pin. If necessary, adjust the stop by loosening the locking ring and grub screw. Put a screwdriver into the slot to rotate the stop to set the angle.



Here you can see the tapered end of the spindle.



With the tapered spindle locked, fit the upper spindle. Use a flat screwdriver to unscrew the locking ring in the centre of the upper spindle. Place the upper spindle over the taper and tighten the retaining screw by passing a 6mm Allen key into the centre of the spindle. Next use a flat screwdriver to tighten the locking ring down onto the head of the retaining screw.
Warning: Failure to tighten the locking ring may result in the arbor and cutter block coming loose.



The router collet is mounted onto the tapered spindle in the same way. When changing the router cutter, take the precaution of checking the centre retaining bolt is tight.

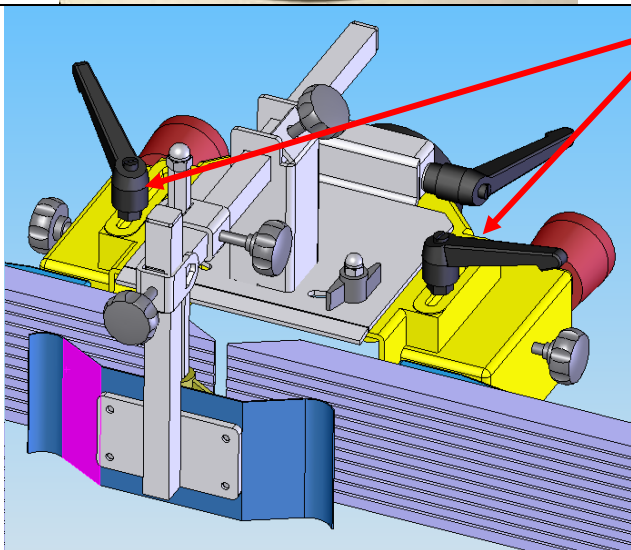

Fit the 2 long bolts through the slots in the hood and then screw them into a pair of holes in the table.

The hood can be fixed in different positions depending on the size of the work piece.

The cover is hinged to provide quick access to the spindle to change the tooling.

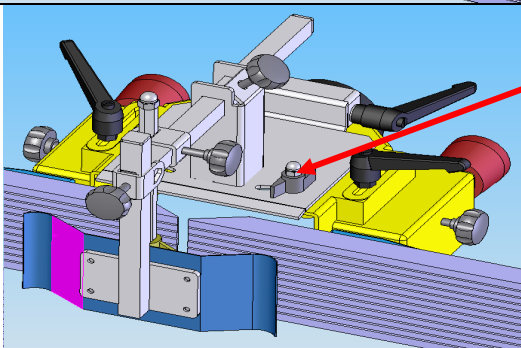

To lock the cover down, unscrew the locking knob, slide the clamp away from the centre of the hood so that the tongue fits under the hood, tighten the locking knob.

Do the same on the other side.

This cover MUST be closed and locked when the machine is in operation.

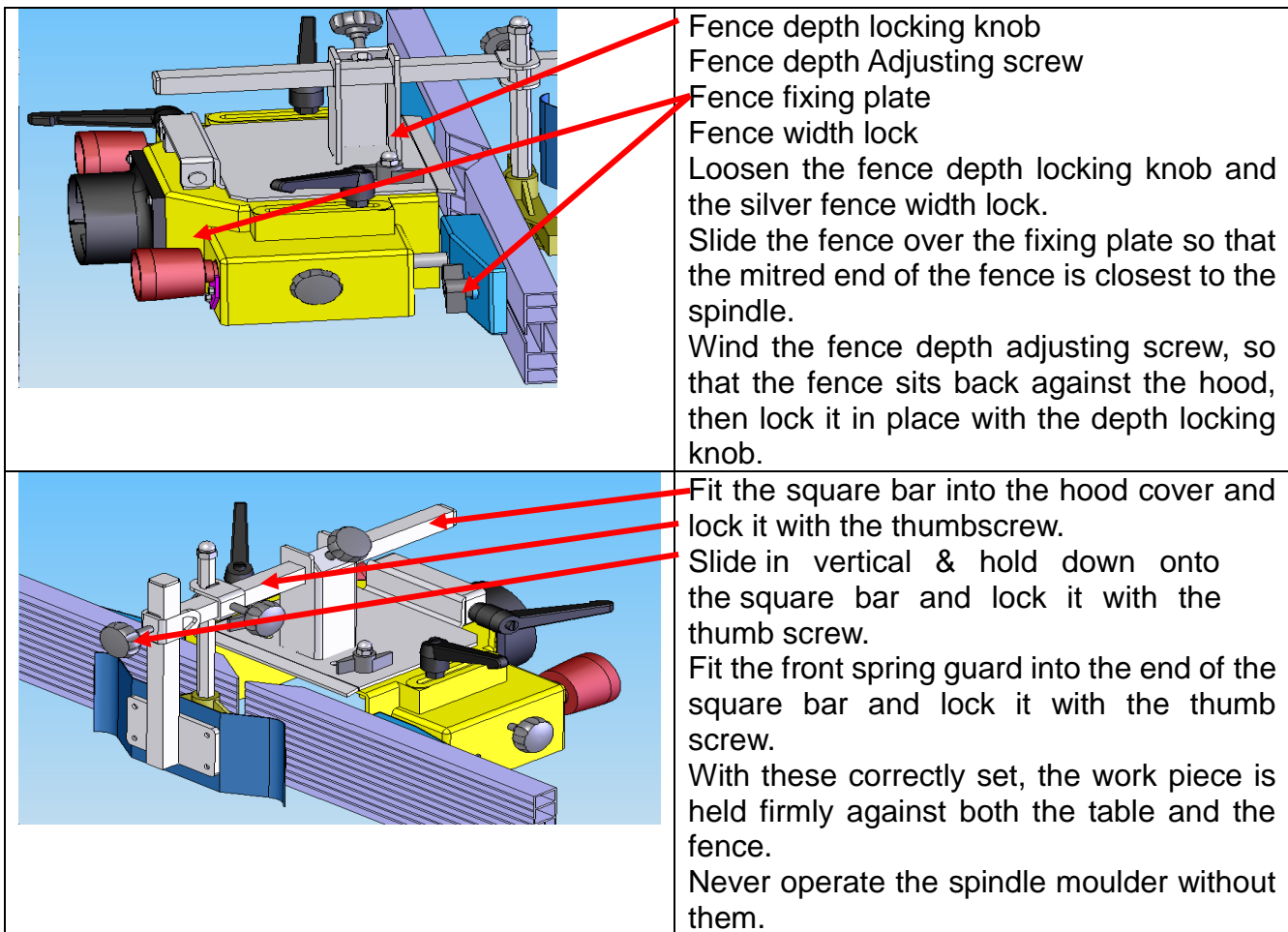

Operating the Spindle Moulder

It is assumed that anyone purchasing a spindle moulder has been trained to operate this type of machine competently. Such training is beyond the scope of this manual. Spindle rotation speeds:

- 1500rpm - Drum Sanding
- 4500rpm - Moulding Hardwoods
- 6500rpm - Moulding Softwoods
- 8500rpm – Routing

It should be noted that sanding and routing accessories are to be purchased as extras.

Limiters: Never use a cutter block without limiters fitted.

Fences: Close the two fences together so the edges are just missing the cutter. This improves the support for the work piece and is best practice for safety reasons.

Always adjust the fences so that the work is fully supported. If the cut removes the whole edge of the work piece, step the out-feed fence forward as appropriate.

- Set the vertical & hold down to contact the top of the work piece.
- Set the front guard spring to hold the work piece up against the fences.
- Use a push stick to feed small work pieces through the cutter block.
- Always feed the work against the direction of rotation (from right to left).

Installing the work stand

1. Take 4 panels and 4 columns from the main carton.
2. Take the following hardware from the work stand hardware bag.
 - 16-Hex head screw M8X20
 - 32-8MM flat washer
 - 16-Hex Nut
3. Assemble the work stand as shown in Fig.1.

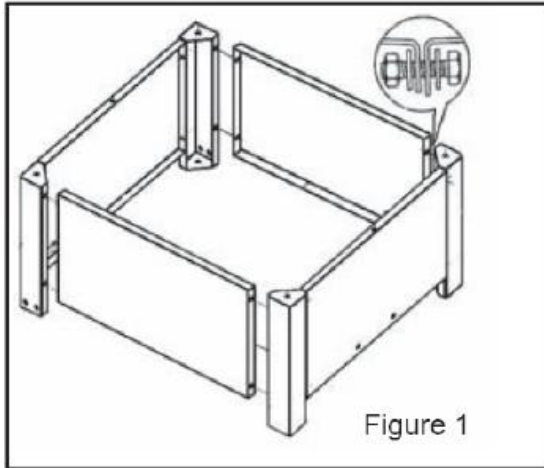

Install the machine housing onto work stand.

WARNING

Do not lift the machine housing without help.

This machine housing is over 70kgs!

Customers should seek assistance to lift this item.

1. Place the machine housing over the thread holes on the work stand.
2. Loosen 1 x star type screw to open the machine housing door and remove 6 x allen bolts to remove the side panel.
3. Take the following hardware from the work stand hardware bag.
 - 4 x hex head screw M8X20
 - 8 x 8mm flat washer
 - 4 x hex nut
4. Secure all screws as shown in figure 2.

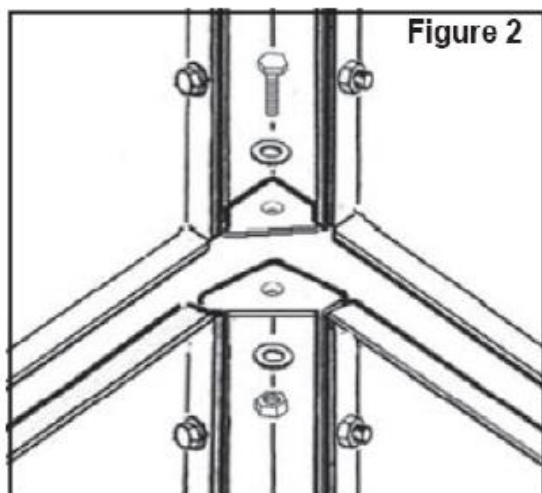

WIRING DIAGRAM

230V

KJD11

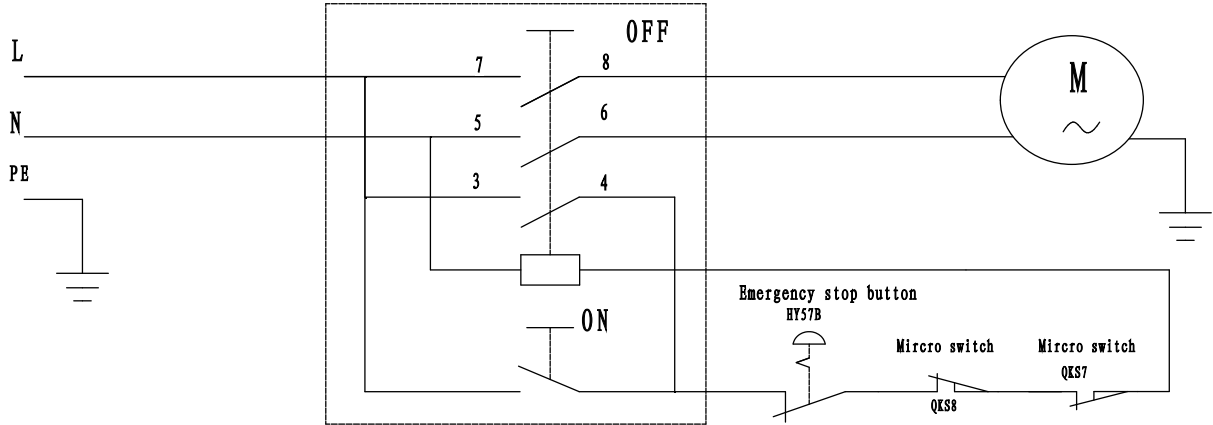
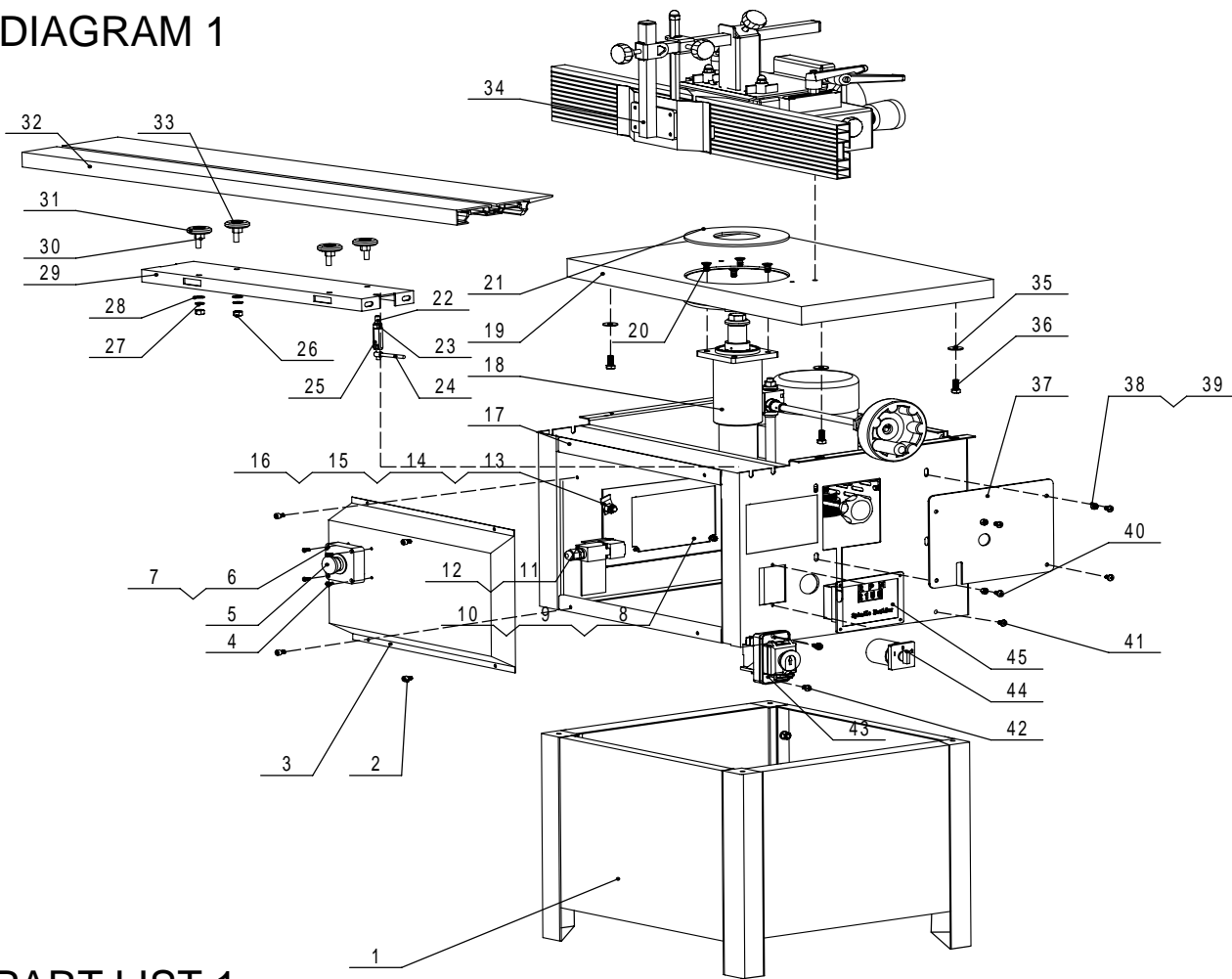

DIAGRAM 1



PART LIST 1

PART#	DESCRIPTION	QTY	PART#	DESCRIPTION	QTY
1	BODY STAND ASSEMBLY	1	24	PULL ROD	1
2	CAP BOLT M5*10	4	25	LOCATING SLEEVE	1
3	PROTECTIVE COVER	1	26	NUT M8	4
4	PHILLIPS SCREW M4*35	4	27	SPRING WASHER 8	4
5	EMERGENCY SWITCH	1	28	FLAT WASHER M10	4
6	EMERGENCY SWITCH COVER	1	29	SUPPORT SEAT	1
7	EMERGENCY SWITCH BOX	1	30	ECCENTRIC SHAFT	4
8	WINDOW	1	31	ROLLER	4
9	PHILLIPS SCREW M5*12	4	32	ALU SLIDING TABLE	1
10	MICRO SWITCH	1	33	AXLE RING 10	4
11	NUT M5	4	34	PROTECION COVER ASSEMBLY	1
12	PHILLIPS SCREW M4*30	2	35	SPRING WASHER 8	4
13	LOCKING PLATE	1	36	HEX BLOT M8*15	4
14	LOCKING HANDLE	1	37	COVER PLATE	1
15	SELF-LOCKING NUT M10	1	38	FLAT WASHER 6	4
16	FLAT WASHER M10	1	39	NUT M6	4
17	BODY ASSEMBLY	1	40	PHILLIPS SCREW M6*12	4
18	MOULDER DRIVING ASSEMBLY	1	41	CAP BOLT M5*8	4
19	WORKING TABLE	1	42	PHILLIPS SCREW M5*12	2
20	SCREW M8*20	4	43	SWITCH KJD11-230V	1
21	SPINDLE COVER RING	1	44	DIVERTER SWITCH	1
22	ANGULAR SETTING ASSEMBLY	1	45	DIGITAL DISPLAY DEVICE	1
23	NUT M14	1			

DIAGRAM 2

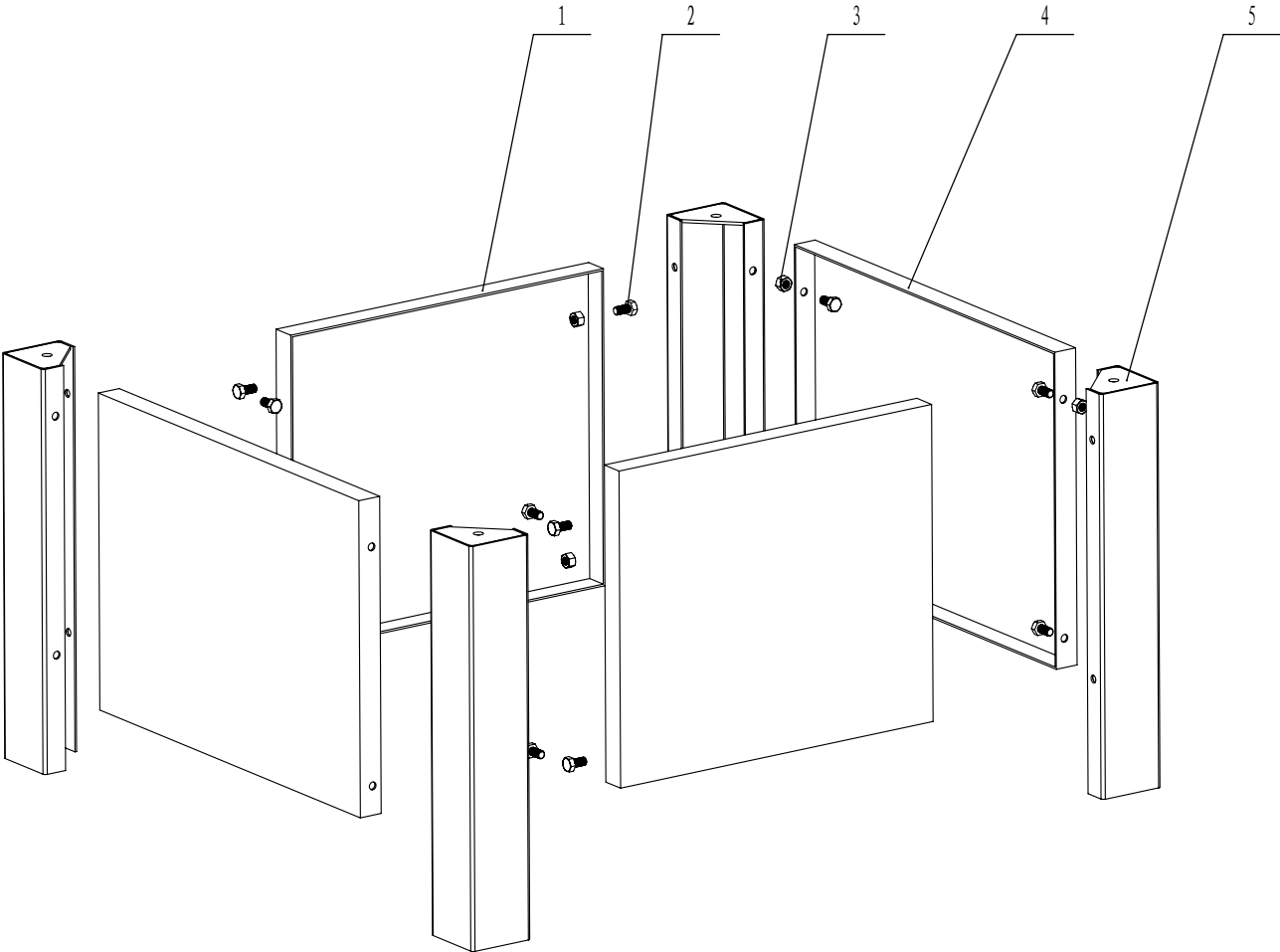

PART LIST 2

PART#	DESCRIPTION	QTY
1	SIDE PLATE	2
2	HEX BOLT M8*16	16
3	NUT M8	16
4	STAND	4
5	LINKING PLATE	2

DIAGRAM 3

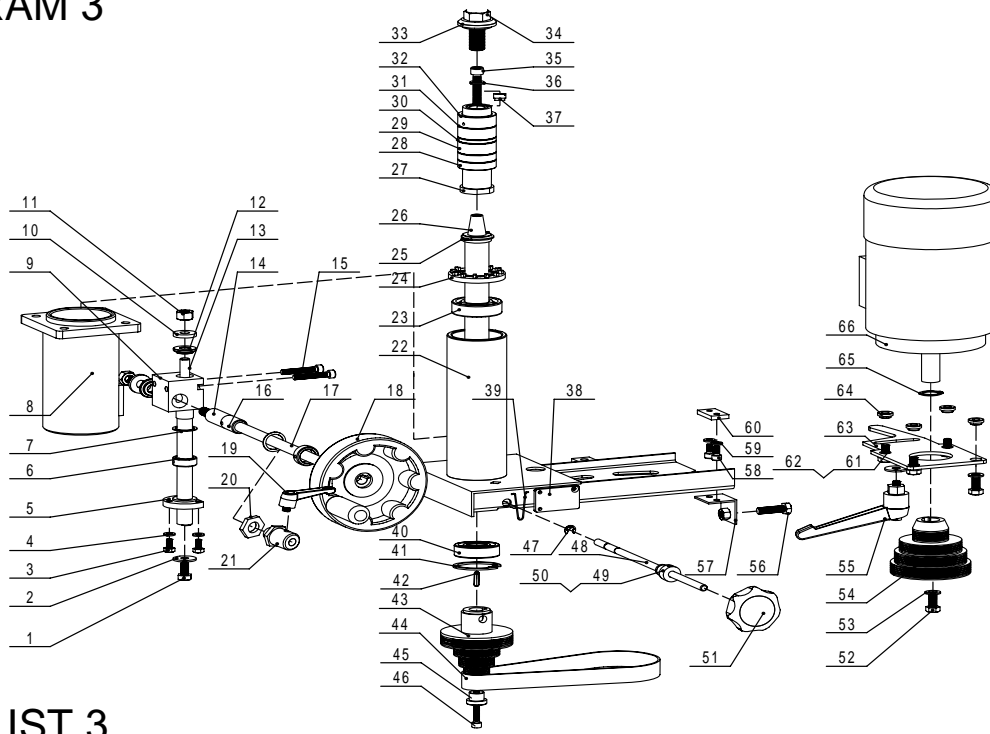

PART LIST 3

PART#	DESCRIPTION	QTY	PART#	DESCRIPTION	QTY
1	HEX BOLT M8*10	1	34	HEX BOLT M16*40	1
2	FLAT WASHER M8	1	35	CAP SCREW M8*40	1
3	HEX BOLT M6*12	3	36	SPRING WASHER M8	1
4	FLAT WASHER M6	3	37	NUT	1
5	NUT BUSH	1	38	PLATE	1
6	GEAR TUBE	2	39	SPRING CLAMP	1
7	BEARING 8103	2	40	BEARING 6204	1
8	LIFTING BUBE BRACKET	1	41	C RING 47	1
9	GEAR BOX	1	42	PIN A5*35	1
10	BEARING	2	43	SPINDLE PULLEY	1
11	NUT M10	2	44	BELT 508J5	1
12	SPINDLE TUBE	2	45	FIX TUBE	1
13	GEAR SHAFT	1	46	CAP SCREW M6*35	1
14	GEAR	1	47	C RING 6	1
15	SCREW M6*40	2	48	CONTROL AXLE	1
16	SPRING PIN 4*25	3	49	SEPARATE TUBE	1
17	HAND WHEEL AXLE	1	50	FLAT HEAD SCREW M6*8	2
18	HAND WHEEL	1	51	LOCKING HANDLE	1
19	LOCKING HANDLE	1	52	BOLT M18	1
20	NUT M20	1	53	FLAT WASHER M8	2
21	LOCKING BUSH	1	54	MOTOR PULLEY	1
22	MOTOR PLATE ASSEMBLY	1	55	LOCKING HANDLE M8*20	1
23	BEARING NSK	1	56	HEX BOLT M8*30	1
24	BEARING CAP	1	57	ANGLE IRON	1
25	BEARING C RING 30	1	58	CAP SCREW M6*12	2
26	SPINDLE	1	59	FLAT WASHER M6	2
27	SHORT SPINDLE 30MM	1	60	NUT PLATE	1
28	SPINDLE WASHER 10	2	61	HEX BOLT M8*20	4
29	SPINDLE WASHER 15	2	62	FLAT WASHER M8	4
30	SPINDLE WASHER 5	3	63	TENSION BLOCK	1
31	SPINDLE WASHER 0.5	10	64	ADJUSTING TUBE	4
32	SPINDLE WASHER	1	65	C RING 19	1
33	SPINDLE CAP	1	66	MOTOR	1

DIAGRAM 4

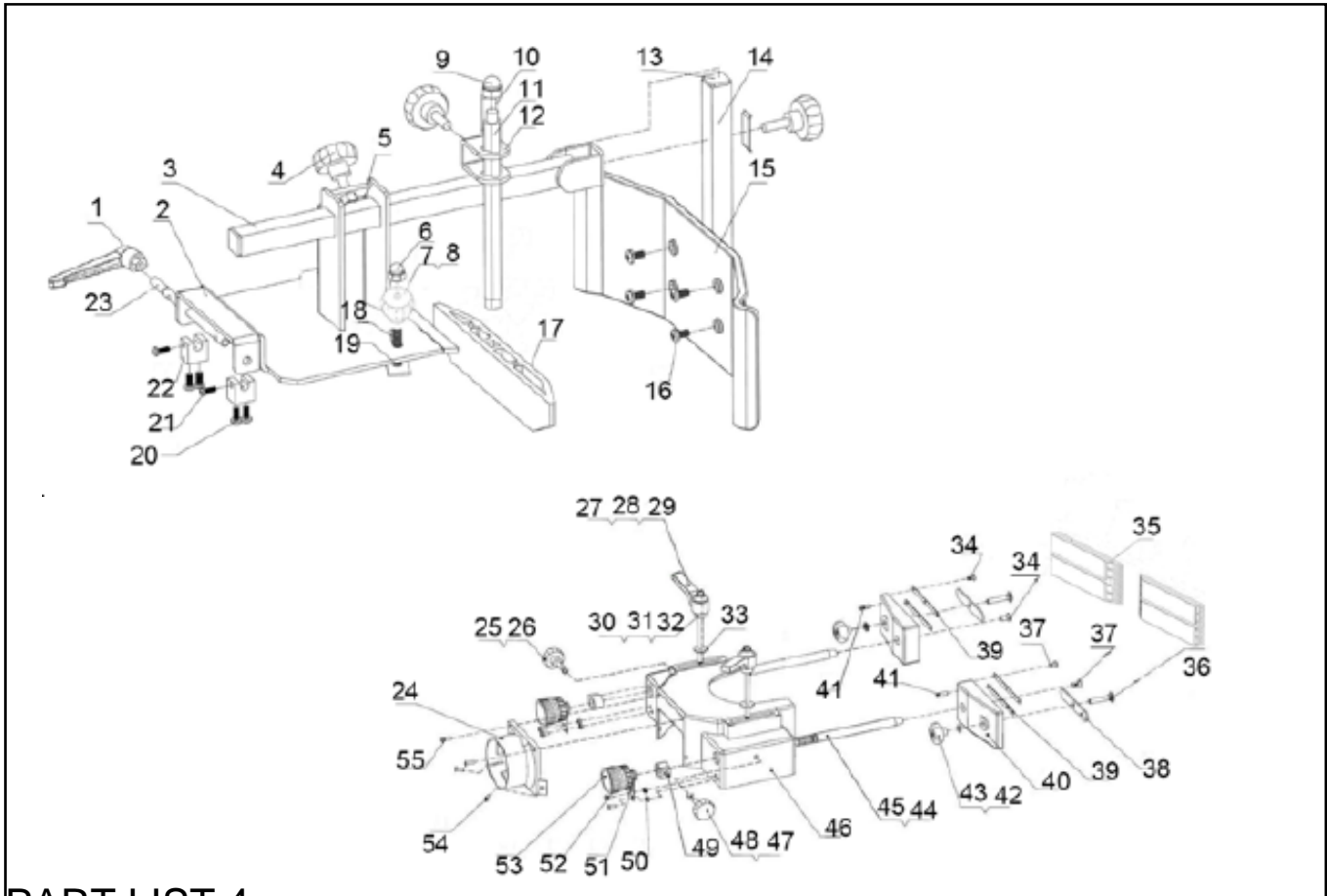

PART LIST 4

PART#	DESCRIPTION	QTY	PART#	DESCRIPTION	QTY
1	LOCKING HANDLE	1	26	LOCKING HANDLE	1
2	EXHAUST COVER	1	27-32	LOCKING HANDLE M8*80*140	2
3	SQUARE LEADER ASSEMBLY	1	33	FLAT WASHER M8	2
4	LOCKING HANDLE	3	34	HEAD SCREW M5*10	6
5	LONG WASHER	1	35	FENCE	2
6	LOCK NUT M8	2	36	BOLT M8*45	2
7	LOCKING HANDLE	2	37	HEAD SCREW M5*10	6
8	FLAT WASHER M8	2	38	SPLINT	2
9	LOCK NUT M10	1	39	BOARD	4
10	HEX SQUARE LEADER	1	40	ACTIVITY BLOCK	2
11	WASHER	1	41	FLAT HEAD SCREW M6*20	8
12	CLAMP PLATE	1	42	LOCKING HANDLE	2
13	SQUARE BLOCK	3	43	FLAT WASHER M8	2
14	STANDPIPE	1	44	GUIDE PLATE ADJUSTING AXLE	2
15	FENCE	1	45	FLAT WASHER M8	2
16	PHILLIPS SCREW M6*12	4	46	EXHAUST SOCKET	1
17	VERTICAL HOLD DOWN	1	47	NUT	1
18	SPRING	2	48	LOCKING HANDLE	1
19	LOCKING BLOCK	2	49	LOCKING BLOCK	2
20	PHILLIPS SCREW M5*12	4	50	NUT M5	4
21	PHILLIPS SCREW M4*12	2	51	BAFFLE	2
22	SMALL SUPPORT	2	52	HEX BOLT M5*16	4
23	SHAFT	1	53	HANDLE WHEEL	2
24	DUST PORT	1	54	PHILLIPS SCREW M5*12	2
25	NUT	1	55	PHILLIPS SCREW M5*16	2

DECLARATION OF CONFORMITY

The Importer:

TOOLSAVE LTD

Unit C, Manders Ind. Est.,
Old Heath Road, Wolverhampton,
WV1 2RP.

Declare that the product:

**Designation: Spindle Moulder
Model: SM8000**

Complies with the following Directives:

Single Spindle Vertical Moulding Machine
See Certificate

Standards & technical specifications referred to:

Ref : **BM EC-Type Examin. Certificate MSD**

Certificate No.	BM 50496437 0001
Report No.	50326757 001

Authorised Technical File Holder: Bill Evans

01/01/2025

The Director



